

### CPU 2 L (left soap dispenser)

Combination dispenser for liquid soaps (S), disinfectants (D) or foam soaps (F) and folded paper towels, stainless steel (AFP) or powder-coated, 1200 ml, approx. 500 - 600 sheets

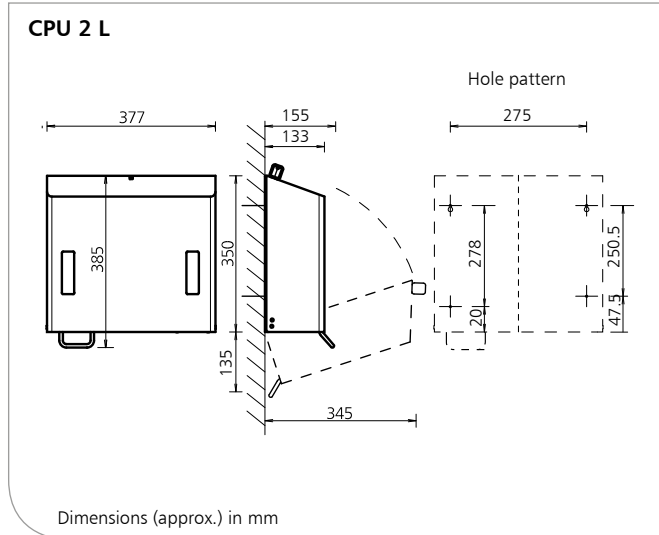

#### Product characteristics

- ▶ Dispenser for dosing liquid soaps and disinfectants (S), low-viscosity hand disinfectants with spray pump (D) or foam soap (F) as well as folded paper towels
- ▶ Refillable container with 1200 ml volume plus overflow quantity
- ▶ Available in right-handed or left-handed form
- ▶ Folded paper capacity approx. 500-600 sheets
- ▶ Housing with sloping lid to prevent foreign objects being placed on the dispenser
- ▶ High-quality and robust stainless steel housing
- ▶ Hygienic and easy-to-clean stainless steel operating lever
- ▶ Hygienic removal – hand contact only with the paper towel
- ▶ Plastic lock with anti-vandalism function
- ▶ Modular system with replaceable container/pump unit, for liquid soaps and disinfectants (S), low-viscosity hand disinfectants with spray pump (D) or foam soap (F)
- ▶ Dispensing quantity approx. 0.7 ml/stroke (D spray pump), approx. 0.7 ml/stroke (F foam pump), approx. 1.5 ml/stroke (S lotion pump)
- ▶ Easily filled from above
- ▶ Open without wall contact
- ▶ Container easily removed for cleaning
- ▶ Viewing window for monitoring filling level
- ▶ Incl. mounting kit for four-point wall mounting

#### Interesting information

References: ▶ Conference centres, exhibitions, airports, train stations, catering, retirement/care homes, hospitals, laboratories, commercial kitchen, food processing, industry, shopping centres, hotels, correctional facilities, schools, kindergartens, sports centres, administration facilities

Application examples:

- ▶ Washrooms, toilets, baths, care and examination rooms, kitchens, entrance areas

#### Technical data

Housing: Stainless steel AISI 304, brushed with Anti-Fingerprint Coating (AFP) or powder-coated white (RAL 9010)

Viewing window: Transparent plastic

Dosing pump: For liquid soaps and disinfectants (S), low-viscosity hand disinfectants with spray pump (D) or foam soap (F), dispensing quantity approx. 0.7 (D) – 0.7 (F) – 1.5 (S) ml/stroke

Operating lever: Stainless steel AISI 304

Lock: Anti-vandalism lock, plastic

Wall mounting: Wall mounting with 4 screws and wall plugs

Description for tender - see overleaf

CPU 2 L/0118/1.1



Subject to technical modifications.  
Tests are required before new filling materials are used!



OPHARDT Hygiene-Technik GmbH + Co. KG  
Lindenau 27 | 47661 Issum | Germany  
Tel.: +49 2835 18-10 | Fax: +49 2835 18-77  
www.ophardt.com | E-Mail: planer@ophardt.com

# CPU 2 L (left soap dispenser)

Combination dispenser for liquid soaps (S), disinfectants (D) or foam soaps (F) and folded paper towels, stainless steel (AFP) or powder-coated, 1200 ml, approx. 500 - 600 sheets

## Description for tender

... Pcs. **SanTRAL® CPU 2 L E S Art. No. 1419953**  
Compact combination dispenser for liquid soaps (1200 ml), and standard folded paper towels (approx. 500 - 600 sheets), left soap dispenser, brushed stainless steel housing with Ophardt hygiene Anti-Fingerprint Coating (AFP), stainless steel back plate, stainless steel operating lever, press-actuation, plastic paper withdrawel, special lock with anti-vandalism function, viewing window for monitoring filling level, removable refillable container, free choice of manufacturers for refill materials, housing with sloped lid to prevent foreign objects being placed on the dispenser  
Dimensions (W x H x D) 377 x 385 x 155 mm

... Pcs. **SanTRAL® CPU 2 L E D Art. No. 1419955**  
Compact combination dispenser for disinfectants for spraying (1200 ml), and standard folded paper towels (approx. 500 - 600 sheets), left soap dispenser, brushed stainless steel housing with Ophardt hygiene Anti-Fingerprint Coating (AFP), stainless steel back plate, stainless steel operating lever, press-actuation, plastic paper withdrawel, special lock with anti-vandalism function, viewing window for monitoring filling level, removable refillable container, free choice of manufacturers for refill materials, housing with sloped lid to prevent foreign objects being placed on the dispenser  
Dimensions (W x H x D) 377 x 385 x 155 mm

... Pcs. **SanTRAL® CPU 2 L E F Art. No. 1419954**  
Compact combination dispenser for foam soaps (1200 ml), and standard folded paper towels (approx. 500 - 600 sheets), left soap dispenser, brushed stainless steel housing with Ophardt hygiene Anti-Fingerprint Coating (AFP), stainless steel back plate, stainless steel operating lever, press-actuation, special lock with anti-vandalism function, viewing window for monitoring filling level, removable refillable container, free choice of manufacturers for refill materials, housing with sloped lid to prevent foreign objects being placed on the dispenser  
Dimensions (W x H x D) 377 x 385 x 155 mm

... Pcs. **SanTRAL® CPU 2 L P S Art. No. 1419956**  
Compact combination dispenser for liquid soaps (1200 ml), and standard folded paper towels (approx. 500 - 600 sheets), left soap dispenser, white (RAL 9010) powder-coated stainless steel housing, stainless steel back plate, stainless steel operating lever, press-actuation, special lock with anti-vandalism function, viewing window for monitoring filling level, removable refillable container, free choice of manufacturers for refill materials, housing with sloped lid to prevent foreign objects being placed on the dispenser  
Dimensions (W x H x D) 377 x 385 x 155 mm

... Pcs. **SanTRAL® CPU 2 L P D Art. No. 1420027**  
Compact combination dispenser for disinfectant for spraying (1200 ml), and standard folded paper towels (approx. 500 - 600 sheets), left soap dispenser, white (RAL 9010) powder-coated stainless steel housing, stainless steel back plate, stainless steel operating lever, press-actuation, special lock with anti-vandalism function, viewing window for monitoring filling level, removable refillable container, free choice of manufacturers for refill materials, housing with sloped lid to prevent foreign objects being placed on the dispenser  
Dimensions (W x H x D) 377 x 385 x 155 mm

... Pcs. **SanTRAL® CPU 2 L P F Art. No. 1419957**  
Compact combination dispenser for foam soaps (1200 ml), and standard folded paper towels (approx. 500 - 600 sheets), left soap dispenser, white (RAL 9010) powder-coated stainless steel housing, stainless steel back plate, stainless steel operating lever, press-actuation, special lock with anti-vandalism function, viewing window for monitoring filling level, removable refillable container, free choice of manufacturers for refill materials, housing with sloped lid to prevent foreign objects being placed on the dispenser  
Dimensions (W x H x D) 377 x 385 x 155 mm

Product: **SanTRAL®**  
Manufacturer: OPHARDT HYGIENE-TECHNIK GmbH + Co. KG

## Compatible accessories

- Drip tray NSU (mounted with dispenser):  
Art. No. 1420578